

WR 400. For Special Applications.

Designed for different multipacks of different quantities. Short format changeover times and an easy operation are standard features of this Petri machine.



WR 400

Design features

Solid tubular frame with central working plane at an ergonomic working height of ca. 800 mm. Safety and noise protection paneling made of 15 mm thick Makrolon. The control cabinet is integrated into the machine paneling..

Working principles

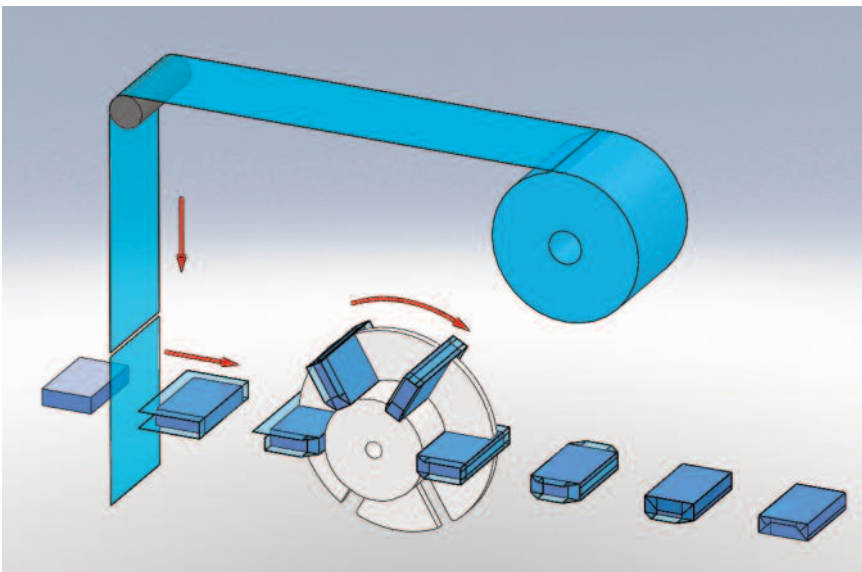

- Film draw-off by means of multi-grip tongs
- Film cut-off by means of rotating carbide cutters
- Infinitely adjustable format range with digital display
- Hardened radial cams
- Low maintenance due to encapsulated bearings and gears

Additional options

- Standard tear-off strip or jumbo tear-off strip with separate drive
- Turning station for film-wrapped product sets at the machine exit

Technical data

- Film length: ca. 400 mm
- Film width: up to 300 mm
- Machine performance: up to 160/min

